

*GPS System 500*

*Antenna Heights & Phase Center Handling*

*October, 2001*

# Table of Contents

---

1.0 introduction .....	3
2.0 System 500...The Mechanical Reference Plane .....	4
3.0 System 500 & SKI-Pro Antenna Heights and Phase Centers .....	5
4.0 System 300...The Mechanical Reference Plane .....	10
5.0 Third party Antenna Heights and Phase Centers.....	11
6.0 Intermixing Antennas .....	12
7.0 A Final note .....	13

---

*Continued on next page*

## 1.0 Introduction

---

### *Overview*

This document describes how to handle GPS antenna heights and different phase centers when using System 500 in a real Time environment and in SKI-Pro. The following topics will be addressed:

- The location of System 500 and System 300 Antenna Mechanical Reference Planes
- The processing of antenna heights and phase center locations in SKI-Pro Antenna Management, Antennas Tab and Site Occupation Intervals
- Using third party GPS antenna heights and phase center locations in SKI-Pro and RTCM real-time positioning.

On close examination of reports that can be generated within SKI-Pro reveal that System 500 and SKI-Pro contain the necessary provisions to properly control, modify and assess the handling of the various GPS antenna models with their calibrated phase center values in order to provide optimal results in both real-time and data post-processing.

---

*Continued on next page*

## 1.0 System 500...The Mechanical Reference Plane

What is the MRP?

Antenna height readings and additional offsets used in SYSTEM-500 real-time positioning and SKI-Pro data processing are referred to the Mechanical Reference Plane (MRP) of a given antenna type. The MRP is a physical plane or mark on the antenna where all heights and phase center offsets are related together. Figure 1 illustrates the MRP of different SYSTEM-500 antenna types.

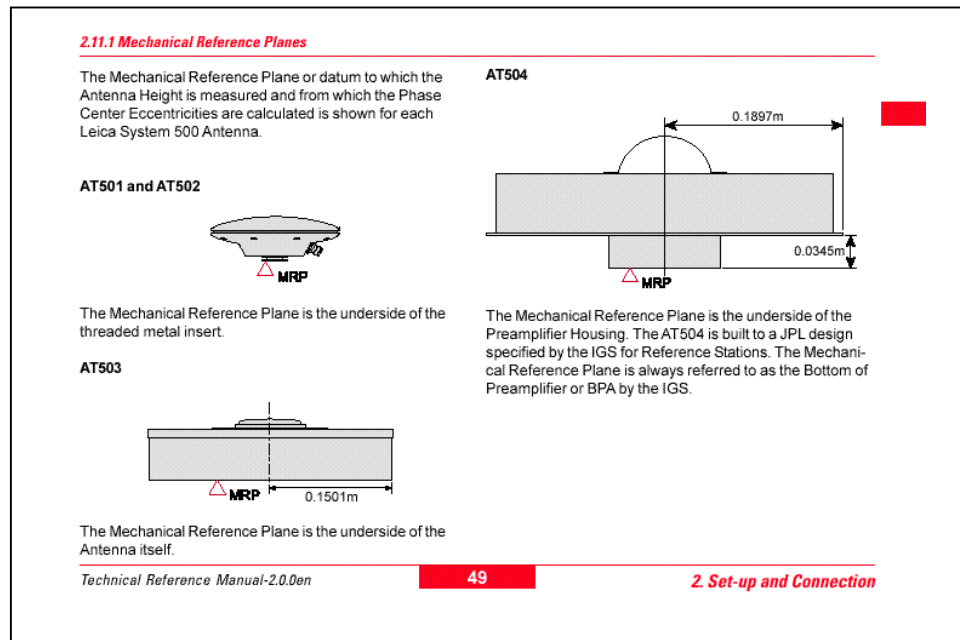

**Figure 1** Mechanical Reference Plane for AT502, AT503 & AT504 Antenna Types

Additional vertical offsets to the initial antenna height values are also used to relate the L1 and L2 phase center locations with respect the selected antenna MRP. The next two sections describe in details the relationships between the user entered antenna height reading, the selected additional vertical offset based on the antenna setup and the Phase Center offsets from calibration values for a given antenna type.

*Continued on next page*

## 2.0 System 500 & SKI-Pro Antenna Heights and Phase Centers

What is the MRP?

System 500 antenna heights and phase center locations are handled as per the different antenna types, setups, MRP locations with their corresponding L1 and L2 vertical phase center calibration values. These values consist of the Vertical Reading (VR) entered by the user, Vertical Offset (VO) corresponding to a specific setup such as: Tripod, Pillar or any other setup with L1 and L2 Vertical Eccentricities (VR1 and VR2 respectively). Figure 2 illustrates the Vertical Reading (VR) from the height hook, Vertical Offset (VO) for the Tripod setup and Vertical Phase Center Eccentricities (VE1 and VE2) with respect to the AT502 MRP.

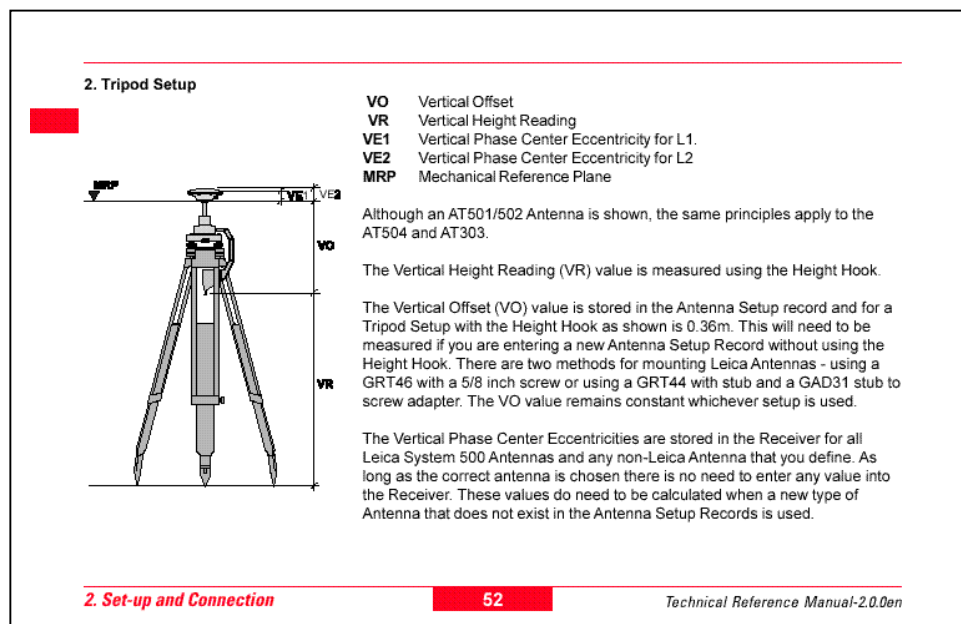

**Figure 2** Relationships between Vertical Reading, Offset and Phase Center Locations for an AT503 Antenna Setup on a Tripod

Additional vertical offsets to the initial antenna height values are also used to relate the L1 and L2 phase center locations with respect the selected antenna MRP. The next two sections describe in details the relationships between the user entered antenna height reading, the selected additional vertical offset based on the antenna setup and the Phase Center offsets from calibration values for a given antenna type.

*Continued on next page*

## 2.0 System 500 & SKI-Pro Antenna Heights and Phase Centers, *Continued*

---

### *Antenna Management in SKI-Pro*

Once GPS raw measurements from System 500 units have been imported into SKI-Pro, the L1 and L2 Vertical Phase Center Eccentricities are immediately assigned to the corresponding values listed in the Antenna Management Phase Center Table. Figure 3 illustrates the different System 300 & System 500 external antenna types, setups and Phase Center locations with respect to their MRP.

**Figure 3** *Vertical and Phase Center Offsets for System 500 & System 300 External Antenna Models*

---

*Continued on next page*

## 2.0 System 500 & SKI-Pro Antenna Heights and Phase Centers, *Continued*

---

*Antenna  
Management in  
SKI-Pro,  
Cont'd...*

When the raw data is inserted in a SKI-Pro project, the total antenna height associated to a given occupation corresponds to the sum of the Vertical Reading (VR) and the Vertical Offset (VO) values. Only the Height Reading (no offset) can be changed in the Antenna Interval Properties panel in the View/Edit Tab. Figure 4 shows the antenna height properties for a given site occupation interval in the View/Edit Tab.

**Figure 4** *Properties of Antenna Height Site Occupation in View/Edit Tab*

---

*Continued on next page*

## 2.0 System 500 & SKI-Pro Antenna Heights and Phase Centers, Continued

### Modifying Properties of Antennas

Vertical Offset, L1 and L1 Phase Center Eccentricity values can be changed within a project by modifying the Properties of the antenna type in the Antennas Tab associated in the project. However, any modifications to the parameters of an antenna type and setup must be done with respect to the definition of the MRP related antenna characteristics. Figure 5 shows the Properties of an antenna type from the Antennas Tab associated to a SKI-Pro project.

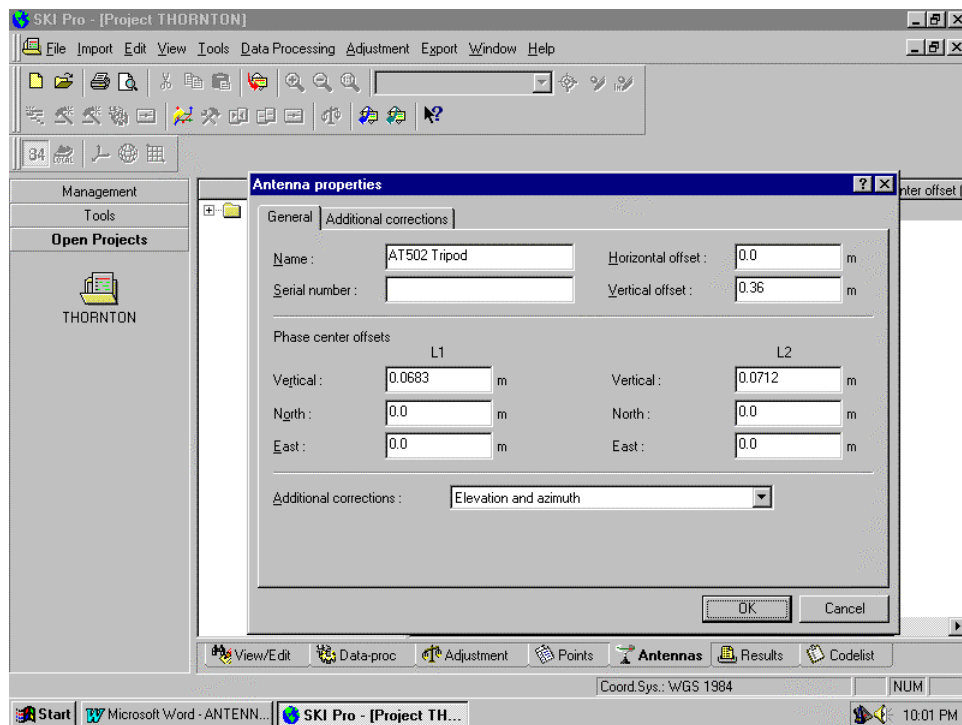

Figure 5 Antenna Type Properties in the Antenna Tab within a given SKI-Pro Project

Continued on next page

## **2.0 System 500 & SKI-Pro Antenna Heights and Phase Centers, Continued**

---

### ***Reporting Antenna Information***

A report on the handling of antenna phase center eccentricities in baseline vector calculations can be selected from the Log File configuration. The different L1 and L2 phase center eccentricities are used to shift phase measurements according to their profile values for different satellite elevation angles together with the relative shift values between the reference and rover antenna types. Figure 6 illustrates the report selection of Antenna Phase Center Eccentricities in SKI-Pro Baseline Log file.

**Figure 6** Report of Phase Center Eccentricities used in SKI-Pro Baseline Data Processing

---

*Continued on next page*

### 3.0 System 300....The Mechanical Reference Plane

---

*What is the MRP?*

System 300 antenna heights and phase center locations are handled in SKI-Pro by **subtracting the thickness of the SR299/399 Internal (0.091 m) or AT202/302 External (0.039 m) antenna from the total height reading**. This subtraction is necessary to reduce the antenna height readings to their MRP so that the L1 and L2 antenna phase center offset values from the SKI-Pro table can be used. The MRP locations of SYSTEM-300 Internal and External antennas are located at the bottom of the antenna housing without the pole or GRT44 adapter. Figure 7 illustrates the locations of the MRP corresponding to the SR299/399 internal and AT202/302 external antennas.

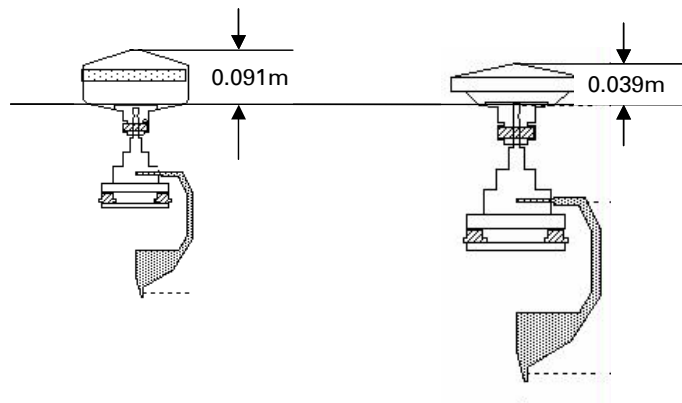

**Figure 7** Mechanical Reference Plane for SR299/399 Internal and AT202/302 External Antennas

---

*Continued on next page*

## 4.0 Third Party Antenna Heights and Phase Centers

---

### *3<sup>d</sup> Party Antennas and SKI-Pro*

Third party GPS antenna heights are usually imported in SKI-Pro via RINEX Data Import. A single antenna height reading referred to the Antenna Reference Plane of the third party GPS antenna is normally provided in the RINEX observation file. The third party vertical phase center locations and their profile values can be used by matching the Antenna Name, Type or Model with the ones contained in the list of the SKI-Pro Antenna Management group.

The International Geodetic Service (IGS) or the National Geodetic Survey (NGS) antenna phase center calibration values can be imported in the SKI-Pro Management group. Third party vertical phase center offset values can also be manually entered. When using third party GPS antenna phase center values with SYSTEM-300 or SYSTEM-500 antenna types, it is advisable to use the IGS or NGS corresponding values since they may slightly differ from the ones internally defined in SKI-Pro. Figure 8 illustrates a list of third party GPS antenna models with their related L1 and L2 Phase Center locations in relation to their respective MRP.

**Figure 8** SR299/SR399 Internal and AT202/#03 External Antenna MRP's

---

*Continued on next page*

## 5.0 Intermixing System 300 & System 500 in Real-Time

---

### *Intermixing Antennas*

Third party GPS antenna types can be used in real-time positioning by setting receivers for RTCM messages. In RTCM, Base Station coordinates are referred to the WGS-84 coordinates of the L1 Antenna Phase Center location. Therefore, no antenna height and offset values are transmitted from the RTCM Base Station. Instead, the WGS-84 Reference Station Ellipsoid height contains the ellipsoid height of the survey marker with the total height reading including the L1 vertical offset value. Figure 9 illustrates the L1 Antenna Phase center location from a Base Station used in RTCM real-time positioning.

**Figure 9** L1 Antenna Phase Center Coordinates transmitted from RTCM Base Station

---

*Continued on next page*

## 6.0 Some Final Notes

---

### *Summary*

GPS antenna heights and phase center locations are critical for both real-time and data post-processing. Antenna heights are referred to a Mechanical Reference Plane (MRP) on the antenna whereas phase center calibration values are located above the MRP. Proper antenna model selection, setup and vertical phase center offsets will provide adequate height solutions between the reference and rover receivers especially when mixing different antenna types in baseline processing. SYSTEM-500 and SKI-Pro contain provisions to properly handle the various GPS antenna models with their calibrated phase center values in order to provide optimal results in both real-time positioning and data post-processing.

---

### *Further Reading*

For further reading on this topic please refer to the following:

- System 300 and System 500 Technical Reference Manuals
  - SKI-Pro On-Line Help
  - RTCM SC-104 Version 2.1 Message Format
  - GPS Newsletter #12 Volume 01
  - GPS Newsletter # 27 & 28 Volume 00
-